

An Amateur Satellite Primer

Tired of the same old QSOs? Break out of orbit and set your course for the "final frontier."

Satellite-active hams compose a relatively small segment of our hobby, primarily because of an unfortunate fiction that has been circulating for many years—the myth that operating through amateur satellites is overly difficult and expensive.

Like any other facet of Amateur Radio, satellite hamming is as expensive as you allow it to become. If you want to equip your home with a satellite communication station that would make a NASA engineer blush, it will be expensive. If you want to simply communicate with a few low-Earth-orbiting birds using less-than-state-of-the-art gear, a satellite station is no more expensive than a typical HF or VHF setup. In many cases you can communicate with satellites using your present station equipment—no additional purchases are necessary.

Does satellite hamming impose a steep learning curve? Not really. You have to do a bit of work and invest some brain power to be successful, but the same can be said of DXing, contesting, traffic handling, digital operating or any other specialized endeavor. You are, after all, communicating with a *spacecraft!*

The rewards for your efforts are substantial, making satellite operating one of the most exciting pursuits in Amateur Radio. There is nothing like the thrill of hearing someone responding to your call from a thousand miles away and knowing that he heard you through a satellite. (The same goes for the spooky, spellbinding effect of hearing your own voice echoing through a spacecraft as it streaks through the blackness of space.) Satellite hamming will pump the life back into your radio experience and give you new goals to conquer.

No doubt this is beginning to sound like an impassioned Captain Kirk delivery.

("Answers! I need *answers*, Mr Spock!")
Let's cut to the chase.

Satellites: Orbiting Relay Stations

Most amateurs are familiar with repeater stations that retransmit signals to provide wider coverage. Repeaters achieve this by listening for signals on one frequency and immediately retransmitting whatever they hear on another frequency. Thanks to repeaters, small, low-power radios can communicate over thousands of square kilometers.

This is essentially the function of an amateur satellite as well. Of course, while a repeater antenna may be as much as a few thousand meters above the surrounding terrain, the satellite is hundreds or thousands of kilometers above the surface of the Earth. The area of the Earth that the satellite's signals can reach is therefore much larger than the coverage area of even the best Earth-bound repeaters. It is this characteristic of



satellites that makes them attractive for communication. Most amateur satellites act either as analog repeaters, retransmitting CW and voice signals exactly as they are received, or as packet store-and-forward systems that receive whole messages from ground stations for later relay.

Linear Transponders and the Problem of Power

Most analog satellites are equipped with *linear transponders*. These are devices that retransmit signals within a band of frequencies, usually 50 to 100 kHz wide, known as the *passband*. Since the linear transponder retransmits the entire band, a number of signals may be retransmitted simultaneously. For example, if three SSB signals (each separated by 20 kHz) were transmitted to the satellite, the satellite

Figure 1—A linear transponder acts much like a repeater, except that it relays an entire group of signals, not just one signal at a time. In this example RS-13 is receiving three signals on its 15-meter uplink passband and retransmitting them on its 10-meter downlink passband.

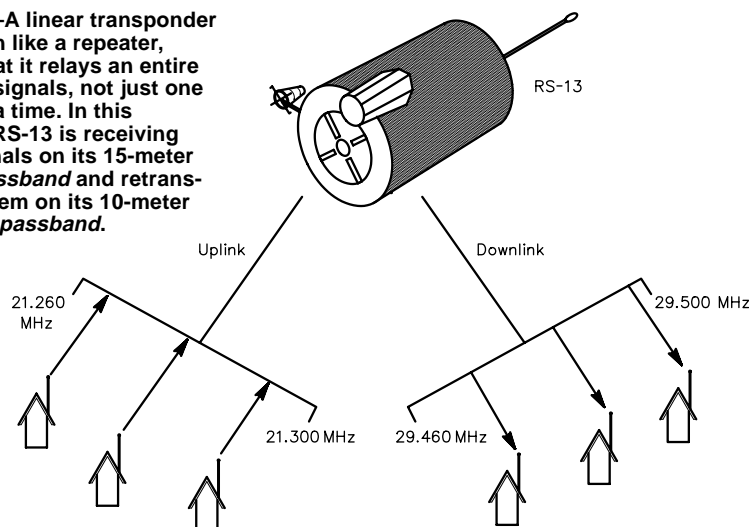

would retransmit all three signals—still separated by 20 kHz each (see [Figure 1](#)). Just like a terrestrial repeater, the retransmissions take place on frequencies that are different from the ones on which the signals were originally received.

Some linear transponders invert the uplink signals. In other words, if you transmit to the satellite at the *bottom* of the uplink passband, your signal will appear at the *top* of the downlink passband. In addition, if you transmit in upper sideband (USB), your downlink signal will be in lower sideband (LSB). Transceivers designed for satellite use usually include features that cope with this confusing flip-flop.

Linear transponders can repeat any type of signal, but those used by amateur satellites are primarily designed for SSB and CW. The reason for the SSB/CW preference has a lot to do with the hassle of generating power in space. Amateur satellites are powered by batteries, which are recharged by solar cells. “Space rated” solar arrays and batteries are expensive. They are also heavy and tend to take up a substantial amount of space. Thanks to meager funding, hams don’t have the luxury of launching satellites with large power systems such as those used by commercial birds. We have to do the best we can within a much more limited “power budget.”

So what does this have to do with SSB or any other mode?

Think *duty cycle*—the amount of time that a transmitter operates at full output. With SSB and CW the duty cycle is quite low. A linear satellite transponder can retransmit many SSB and CW signals while still operating within the power generating limitations of an amateur satellite. It hardly breaks a sweat.

Now consider FM. An FM transmitter operates at a 100% duty cycle, which means it is generating its full output with every transmission. Imagine how much power a linear transponder would need to retransmit, say, a dozen FM signals—all demanding 100% output!

Having said all that, there *are* a few FM repeater satellites. However, these are very low-power satellites (typically less than 1 W output) and they do not use linear transponders. They retransmit only one signal at a time.

Finding a Satellite

Before you can communicate through a satellite, you have to know when it is available. This isn’t quite as straightforward as it seems.

Amateur satellites do not travel in geostationary orbits like many commercial and military spacecraft. Satellites in geostationary orbits cruise above the Earth’s equator at an altitude of about 35,000



A portable antenna array for working OSCAR 10. The array consists of a 2-meter Yagi, a 70-cm Yagi, and an azimuth/elevation rotator.

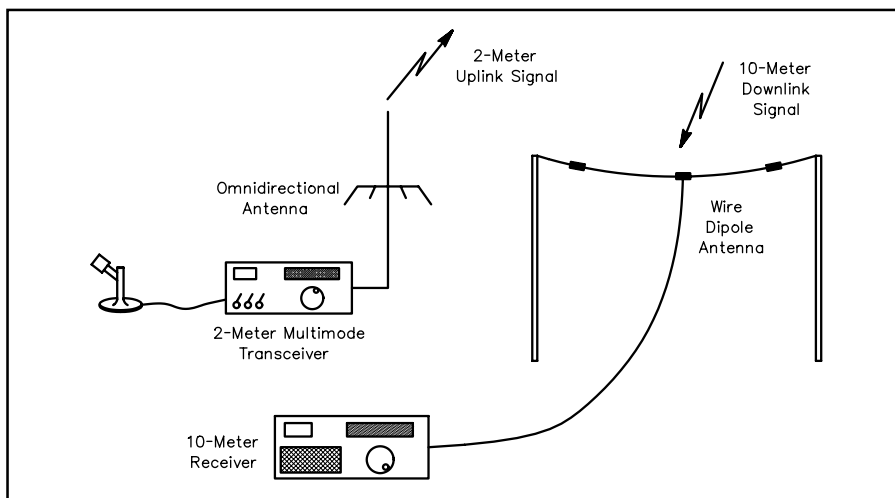

To work RS13 or RS15 by uplinking on 2 meters you’ll need a 2-meter multimode transceiver, a 10-meter receiver and antennas for 2 and 10 meters.

kilometers. From this vantage point the satellites can “see” almost half of our planet. Their speed in orbit matches the rotational speed of the Earth itself, so the satellites appear to be “parked” at fixed positions in the sky. They are available to send and receive signals 24 hours a day over an enormous area.

Of course, amateur satellites *could* be placed in geostationary orbits. The problem isn’t one of physics; it’s money and politics. Placing a satellite in geostationary orbit and keeping it on station costs a great deal of money—more than any one amateur satellite organization can afford. An amateur satellite group could ask similar groups in other areas of the world to contribute money to a geostationary satellite project, but why

should they? Would you contribute large sums of money to a satellite that may never “see” your part of the world? Unless you are blessed with phenomenal generosity, it would seem unlikely!

Instead, all amateur satellites are either low-Earth orbiters (LEOs), or they travel in very high, elongated orbits. Either way, they are not in fixed positions in the sky. Their positions relative to your station change constantly as the satellites zip around the Earth. This means that you need to predict when satellites will appear in your area, and what paths they’ll take as they move across your local sky.

You’ll be pleased to know that there is software available that handles this prediction task very nicely. A bare-bones

program will provide a schedule for the satellite you choose. A very simple schedule might look something like this:

Date	Time	Azimuth	Elevation
10 OCT 01	1200	149°	4°
10 OCT 01	1201	147°	8°
10 OCT 01	1202	144°	13°
10 OCT 01	1203	139°	20°

The date column is obvious: 10 October 2001. The time is usually expressed in UTC. This particular satellite will appear above your horizon beginning at 1200 UTC. The bird will “rise” at an azimuth of 149°, or approximately southeast of your station. The elevation refers to the satellite’s position above your horizon in degrees—the higher the better. A zero-degree elevation is right on the horizon; 90° is directly overhead.

By looking at this schedule you can see that the satellite will appear in your southeastern sky at 1200 UTC and will rise quickly to an elevation of 20° by 1203. The satellite’s path will curve further to the east as it rises. Notice how the azimuth shifts from 149° at 1200 UTC to 139° at 1203.

The more sophisticated the software, the more information it usually provides in the schedule table. The software may also display the satellite’s position graphically as a moving object superimposed on a map of the world. Some of the displays used by satellite prediction software are visually stunning!

Satellite prediction software is widely available on the Web. Some of the simpler programs are freeware. My recommendation is to browse the AMSAT-NA site at <http://www.amsat.org>. They have the largest collection of satellite software for just about any computer you can imagine. Most AMSAT software isn’t free, but the cost is reasonable and the funds support amateur satellite programs.

Whichever software you choose, there are two key pieces of information you must provide before you can use the programs:

(1) **Your position.** The software must have your latitude and longitude before it can crank out predictions for your station. The good news is that your position information doesn’t need to be extremely accurate. Just find out the latitude and longitude of your city or town (the public library would have this data, as would any nearby airport) and plug it into the program.

(2) **Orbital elements.** This is the information that describes the orbits of the satellites. You can find orbital elements (often referred to as *Keplerian elements*) at the AMSAT Web site, and through many other sources on the Internet. You need to update the elements every few months. Many satellite programs will automatically read in the elements if they are provided as ASCII text files. The less sophisticated programs will require you to enter them by

hand. I highly recommend the automatic-update software. It’s too easy to make a mistake with manual entries.

Getting Started with the FM Birds

Do you like elevated FM repeaters with wide coverage areas? Then check out the AMRAD-OSCAR 27, UoSAT-OSCAR 14 and SunSat-OSCAR 35 FM repeater satellites. From their low-Earth orbits these satellites can hear stations within a radius of 2000 miles in all directions.

You can operate the FM satellites with a basic dual-band VHF/UHF FM transceiver. Assuming that the transceiver is reasonably sensitive, you can use an omnidirectional antenna such as a dual-band ground plane or something similar. Some amateurs have even managed to work the FM birds with H-Ts,

but they often couple their radios to multi-element directional antennas. Of course, this means that they must aim their antennas at the satellites as they cross overhead.

Start by booting your satellite tracking software. Check for a pass with a peak elevation of 30° or higher. As with all satellites, the higher the elevation, the better. If you plan to operate outdoors or away from home, either print the schedule to a printer or jot down the times on a piece of scrap paper that you can keep with you.

When the satellite comes into range, you’ll be receiving its signal about 5 kHz higher than the published downlink frequency (see Table 1) thanks to *Doppler shifting* (see the sidebar, “Down with Doppler”). So, begin listening on the higher frequency. If you suddenly hear the noise

Table 1

Active Amateur Satellites: Frequencies and Modes

Satellite	Uplink (MHz)	Downlink (MHz)
SSB/CW		
AMSAT-OSCAR 10	435.030—435.180	145.825—145.975
Fuji-OSCAR 20	145.900—146.000	435.800—435.900
		435.795 (CW beacon)
Fuji-OSCAR 29 (available biweekly)	145.900—146.000	435.800—435.900
RS-13	21.260—21.300	435.795 (CW beacon)
	145.960—146.000	29.460—29.500
RS-15	145.858—145.898	29.458 (CW beacon)
		29.354—29.394
Packet—1200 bit/s (FM FSK uplink, PSK downlink except as noted)		
AMSAT-OSCAR 16	145.90, .92, .94, .96	437.0513
Packet—9600 bit/s (FM FSK uplink and downlink.)		
UoSAT-OSCAR 22	145.900, .975	435.120
KITSAT-OSCAR 25	145.98	436.50
Fuji-OSCAR 29	145.85, .87, .89, .91	435.910
TMSAT-OSCAR 31	145.925	436.925
UoSAT-OSCAR 36	145.960	437.025, 437.400
FM Voice Repeaters		
UoSAT-OSCAR 14	145.975	435.070
AMRAD-OSCAR 27 (daylight passes <i>only</i>)	145.850	436.795
SUNSAT-OSCAR 35 (limited operation)	436.290	145.825

Down with Doppler

The relative motion between you and the satellite causes *Doppler shifting* of signals. As the satellite moves toward you, the frequency of the downlink signals will increase as the velocity of the satellite adds to the velocity of the transmitted signal. As the satellite passes overhead and starts to move away from you, the frequency will drop, much the same way as the tone of a car horn or a train whistle drops as the vehicle moves past the observer.

The Doppler effect is different for stations located at different distances from the satellite because the relative velocity of the satellite with respect to the observer is dependent on the observer’s distance from the satellite. The result is that signals passing through the satellite transponder shift slowly around the published downlink frequency. Your job is to tune your uplink transmitter—*not your receiver*—to compensate for Doppler shifting and keep your frequency relatively stable on the downlink. That’s why it is helpful to hear your own signal coming through the satellite. If you and the station you’re talking to both compensate correctly, your conversation will stay at one frequency on the downlink throughout the pass. If you don’t compensate, your signals will drift through the downlink passband as you attempt to “follow” each other. This is highly annoying to others using the satellite because your drifting signals may drift into their conversations.

level dropping, chances are you are picking up the satellite's signal. At about the midpoint of the pass you'll need to shift your receiver down to the published frequency, and as the satellite is heading away you may wind up stepping down another 5 kHz. Some operators program these frequency steps into memory channels so that they can compensate for Doppler shift at the push of a button.

Once again, these FM satellites behave just like terrestrial FM repeaters. Only one person at a time can talk. If two or more people transmit simultaneously, the result is garbled audio or a squealing sound on the output. The trick is to take turns and keep the conversations short. Even the best passes will only give you about 15 minutes to use the satellite. If you strike up a conversation, don't forget that there are others waiting to use the bird.

The FM repeater satellites are a good way to get started. My recommendation would be to try OSCAR 14 or OSCAR 27 first. SunSat-OSCAR 35 operates on a somewhat variable schedule and may be difficult to catch. See the SunSat Web page at <http://sunsat.ee.sun.ac.za/> for the latest schedules.

Once you get your feet wet, you'll probably wish you could access a satellite that wasn't so crowded, where you could chat for as long as the bird was in range. Time to move up!

Moving Up to the Fujis and Radio Sputniks

The RS—*Radio Sputnik*—satellites were built and launched by the former Soviet Union. There have been a number of RS satellites in orbit. At the time of this writing, only RS-13 and RS-15 are operating.

RS-13 is by far the more popular of the two active Radio Sputniks. It is actually a transponder module riding piggyback, so to speak, on much larger navigational bird. RS-13 carries a *Mode K* transponder, which means that it receives signals on the 15-meter band and retransmits on the 10-meter band. RS-13 also operates in *Mode A*, which means that it receives on 2 meters and retransmits on 10 meters.

When using RS-13 you don't need to know precisely where the satellite is positioned in the sky. After all, you aren't likely to be using narrow beamwidth antennas unless you're trying to uplink on 2 meters using a Yagi. Mainly, you want to know when the satellite will be in view. Of course, 15 and 10-meter signals are subject to ionospheric bending, so it pays to listen for the satellite before and after the predicted visibility period.

Once you've determined when the satellite is due to rise above the horizon at your location, listen for the satellite's CW telemetry beacon. This signal is transmitted

constantly by the satellite and carries information about the state of the satellite's systems, such as its battery voltage, solar-panel currents, temperatures and so on. You should hear it just as the satellite rises above the horizon. As soon as you can hear the beacon, start tuning across the downlink passband.

On an active day you should pick up several signals (you can hear recordings of actual RS-13 signals in the Amateur Radio section of my personal Web site at <http://home.att.net/~wb8imy/home.htm>). They will sound like normal amateur SSB and CW conversations. Nothing unusual about them at all—except that the signals will be slowly drifting downward in frequency. That's the effect of Doppler shift. It's not too serious on the 10-meter downlink, but it can be a challenge when the downlink is at 70 cm because the degree of shift is proportional to the transmitted frequency—the higher the frequency, the greater the shift.

Now tune your transmitter's frequency to the satellite's uplink passband (on either 15 or 2 meters). RS-13 does not use inverting transponders. If you transmit at the low end of the uplink passband, you can expect to hear your signal at the low end of the downlink passband. Discounting the effects of Doppler, the relationship between your uplink and downlink frequency is fairly direct. For example, if you transmit at 21.265 MHz you can expect your signal to be retransmitted by the satellite at 29.465 MHz. Generally speaking, CW operators occupy the lower half of the transponder passband while SSB enthusiasts use the upper half.

Assuming that you cannot hear your own signal from the satellite on a separate receiver, the best thing to do is make your best guess as to where your signal will appear on the downlink and set your receive frequency accordingly. Send several brief CQs ("CQ RS-13, CQ RS-13..."), tuning "generously" around your guesstimated receive frequency after each one. The station that is answering your call will also be making his or her best guess about where you are listening.

RS-15 operates in the same fashion, but listens only on 2 meters and retransmits on 10 meters. Unfortunately, RS-15 has been suffering from a damaged power system. As a result, its signal is often very weak.

Fuji OSCARs 20 and 29 are also linear transponder birds that function much like RS-13 and RS-15. The main difference is that they listen on 2 meters and retransmit on 70 cm. (They also use inverting transponders.) Not that many amateurs own receivers that can listen for 70-cm CW and SSB, so these satellites are not very active. During weekend passes, however, you should be able

to hear several conversations taking place.

Station Requirements for the RS and Fuji Satellites

To work RS-13 you'll need, at minimum, a multiband HF SSB or CW transceiver. You *do not* need an amplifier; 100 W is more than enough power for the uplink. In fact, even 100 W may be too much in many instances. The rule of thumb is that your signal on the downlink should never be stronger than the satellite's own telemetry beacon.

A 15-meter wire dipole is adequate for sending and receiving with RS-13. (Yes, you'll be listening on 10 meters, but the 15-meter dipole should function adequately as a 10-meter receiving antenna.)

The ideal situation is to have *separate* 15- and 10-meter radios and antennas so that you can listen on 10 meters while you are transmitting on 15 meters. The ability to hear yourself simultaneously on the downlink is a tremendous asset for working any satellite. It allows you to operate full duplex as you listen to the Doppler shifting of your own signal, giving you the opportunity to immediately tweak your transmit frequency to compensate (rather than fishing for contacts using the haphazard half-duplex procedure I described earlier).

To work RS-13 and RS-15 in Mode A, you'll need a 2-meter multimode transceiver that can operate in CW or SSB. Remember that in Mode A RS-13 and RS-15 are listening for signals on 2 meters and retransmitting on 10 meters. This means that you'll still need a 10-meter SSB receiver. Choose your radios carefully. A number of modern HF transceivers also include 2 meters and even 70 cm. The problem, however, is that some of these radios do not allow *crossband splits* between VHF and HF. That is, they won't allow you to transmit on 2 meters and receive on 10 meters. At the very least they won't allow you to do this simultaneously.

Omnidirectional antennas for 2 meters are sufficient for transmitting to RS-13 and RS-15. A beam on 2 meters would be even better, but then you incur the cost of an antenna rotator that can move the antenna up and down as well as side to side—the so-called *azimuth/elevation rotator*.

For the Fuji OSCARs the ability to transmit and receive simultaneously is a must, in my opinion. The Doppler effect is pronounced on the 70-cm downlink. You need to listen to your own signal continuously, making small adjustments to your 2-meter uplink so that your voice or CW note does not slide rapidly downward in frequency. To achieve this you will need separate 2-meter and 70-cm transceivers (such as a couple of used rigs), or a dual-band transceiver that is specifically designed for satellite use. Kenwood, ICOM

and Yaesu have such radios in their product lines. These wondrous rigs make satellite operating a breeze, although their price tags may give you a bit of sticker shock (about \$1600). They feature full crossband duplex, meaning that you can transmit on 2 meters at the same time you are listening on 70-cm. They even have the ability to work with inverting transponders automatically. That is, as you move your receive frequency down, the transmit VFO will automatically move up (and vice versa)!

Although beam antennas and azimuth/elevation rotators are not strictly necessary to work the Fujis (I've done it myself with omnidirectional antennas on both bands), they vastly improve the quality of your signal. If you decide to go the omnidirectional route, you'll need to add a 70-cm receive preamp at the antenna to boost the downlink signal.

Taking the High Road with OSCAR 10

The limitations of LEO satellites, especially their brief periods of availability, are overcome by a class of satellites called "Phase 3." The name comes from the various phases in the development of amateur satellites. The earliest ones, during Phase 1, contained beacon and telemetry transmitters, but not transponders. These early satellites were all in circular, low-Earth orbits—as were the Phase 2 satellites, which carried communication transponders.

Phase 3 satellites are not in low-Earth orbits. Rather, their orbits describe an ellipse. These satellites swing within a few hundred kilometers of the Earth's surface at one end of the ellipse (the *perigee*) and streaks out to 30,000 km or so at the other end (the *apogee*). The physics of an orbiting body dictates that the satellite spends much more of its time near apogee than perigee. Therefore, the Phase 3 satellites spend most of their time at very high altitudes. From a typical point in the Northern Hemisphere, a particular Phase 3 satellite is available for more than 10 hours per day. This is a remarkable improvement over the LEO satellites! And because the Phase 3 satellite is so much higher, it is visible from a greater fraction of the Earth's surface, too. The result is a vast improvement in the communications capability of the satellite.

There is a downside, however. The greater distance to the Phase 3 satellite means that more transmitted power is needed to access it, and a weaker signal is received from the satellite at the ground station. (This problem is alleviated somewhat by the use of gain antennas on the satellite.) The signal levels are such that you usually need ground-station antennas that exhibit significant gain (10 dBi or more).

At the time of this writing, the only Phase 3 satellite in orbit is OSCAR 10. It

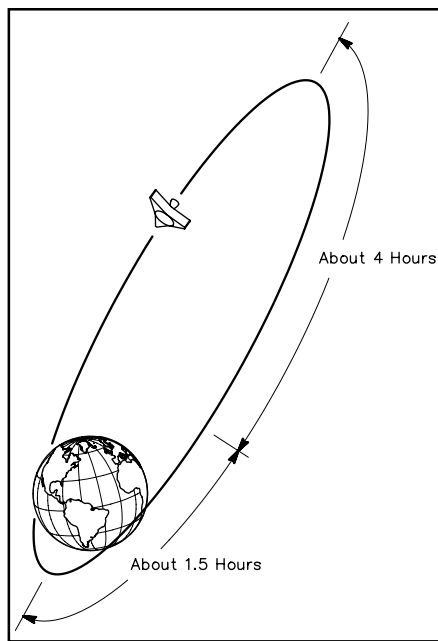

OSCAR 10 travels in a high, elliptical orbit. Phase 3D will achieve a similar orbit.

is only intermittently available; its computer suffered accumulated radiation damage that rendered the satellite uncontrollable. OSCAR 10 occasionally operates when it gets sufficient sunlight.

When OSCAR 10 is working, however, it is a hot DX satellite! At apogee OSCAR 10 can see half of the globe. This means that you can enjoy transatlantic and transpacific conversations for hours at a time.

Such astonishing capability comes at a price in terms of station hardware. Not only will you need Yagi antennas and an az/el rotator, you will also need a VHF/UHF dual-band "satellite ready" SSB transceiver, a 150-W amplifier and a receive preamplifier. If you buy brand-new equipment, the cost of a station for OSCAR 10 could approach \$3000. Some careful shopping at flea markets and on the Web can bring the cost down to about \$1500.

Phase 3D—The SuperSat

Late last year the amateur satellite community received the happy news that Phase 3D, the largest, most expensive Amateur Radio satellite ever created, finally had a launch commitment. If everything goes as planned, Phase 3D will be launched in the very near future.

Like OSCAR 10, Phase 3D is designed to travel in a high, elongated orbit that will provide spectacular DX coverage. Phase 3D will be a huge (by amateur satellite standards) communication platform offering transponders—both analog and digital—from HF to microwave!

The RF output of its 2-meter transmitter alone will be about 200 W. Compare that to the 50-W output of OSCAR 10 on 2



The Phase 3D satellite, buttoned up and ready to go.

meters. This isn't the whole story, though. OSCAR 10's 2-meter antenna offers an effective radiated power (ERP) of 180 W. The superior 2-meter antennas aboard Phase 3D are capable of yielding an ERP of up to 2500 W!

What does this mean to you? It means that you won't need the large multielement beam antennas you're accustomed to seeing on most OSCAR 10 stations. Depending on the sensitivity of your receiver you may not even need a mast-mounted receive preamp.

Phase 3D will pack a substantial punch on all of its transponders making large, expensive stations for high-orbiting amateur satellites things of the past. This will be especially true if you take advantage of Phase 3D's microwave capability.

Like most satellite operators I'm eagerly awaiting news about the launch of Phase 3D. When that powerful spacecraft reaches orbit, a new era of satellite hamming will begin.

The PACSATs

If you enjoy packet operating, you'll love the PACSATs! Several satellites comprise the currently active PACSAT armada: AMSAT-OSCAR 16, UoSat-OSCAR 22, KITSAT-OSCAR 25, Fuji-OSCAR 29, TMSAT-OSCAR 31 and UoSAT-OSCAR 36.

Most PACSATs work like temporary mail boxes in space. You upload a message or a file to a PACSAT and it is stored for a time (days or weeks) until someone else—possibly on the other side of the world—downloads it. Many PACSATs are also equipped with on-board digital cameras. They snap fascinating images of the Earth, which are stored as files that you can download and view. Read "Step Up to the 38,400 Bps Digital Satellites" by Stacey Mills, W4SM, elsewhere in this issue.

Which PACSAT is Best?

You can divide the PACSATs into two types: The 1200- and 9600-baud satellites. OSCAR 16 is presently the only 1200-baud PACSAT available for message storing and forwarding (OSCAR 19 may be coming back on line shortly). You transmit packets

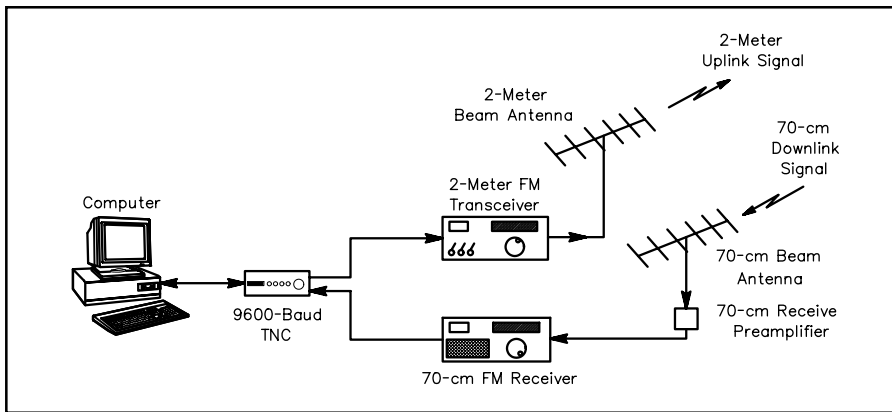

This is a diagram of a typical 9600-baud packet satellite station. Both the 2-meter and 70-cm radios must be capable of handling 9600-baud data signals.

to AO-16 on 2-meter FM and receive on its phase-shift keying (PSK) signal on 435-MHz SSB. OSCARs 22, 25, 29, 31 and 36 are the 9600-baud PACSATs. You send packets to them on 2-meter FM and receive on 435-MHz FM.

So which PACSATs are best for beginners? There's no easy answer for that question. You can use any 2-meter FM transceiver to send data to a 1200-baud PACSAT, but getting your hands on a 435-MHz SSB receive could put a substantial dent in your bank account (although you could receive the signal on an HF rig by using a receive converter). In addition, you need a special PSK terminal node controller (TNC). These little boxes are not common and could set you back about \$250.

So the 9600-baud PACSATs are best for the newbie, right? Not so fast. It's true that you don't need a special packet TNC. Any of the affordable 9600-baud TNCs will do the job. The catch is that not all FM transceivers are usable for 9600-baud packet. You need rigs (or a single dual-band radio) capable of handling 9600-baud signals. And not all 440-MHz FM transceivers can receive down to the 435-MHz neighborhood of the PACSATs. As always, shop carefully.

Broadcasting Data

Despite the huge amounts of data that can be captured during a pass, there is considerable competition among ground stations about exactly *which* data the satellite should receive or send! There are typically two or three dozen stations within a satellite's roving footprint, all making their various requests. If you think this sounds like a recipe for chaos, you're right.

The PACSATs produce order out of anarchy by creating two *queues* (waiting lines)—one for uploading and another for downloading. The upload queue can accommodate two stations and the download queue can take as many as 20. Once the

satellite admits a ground station into the queue for downloading, the station moves forward in the line until it reaches the front, whereupon the satellite services the request for several seconds.

For example, let's say that OSCAR 16 just accepted me, WB8IMY, into the download queue. I want to grab a particular file from the bird, but I have to wait my turn. OSCAR 16 lets me know where I stand by sending an "announcement" that I see on my monitor. It might look like this:

WB8ISZ AA3YL KD3GLS WB8IMY

WB8ISZ is at the head of the line. The satellite will send him a chunk of data, then move him to the rear.

AA3YL KD3GLS WB8IMY WB8ISZ

Now there are only two stations ahead of me. When I reach the beginning of the line, I'll get my share of "attention" from the satellite.

You may not be able to download an entire file in one shot. If the satellite disappears over the horizon before you receive the complete file, there's no need to worry. Your PACSAT software "remembers" which parts of the file you still need from the bird. When it appears again, your software can request that these "holes" be filled.

And while all of this is going on, *you're receiving data that other stations have requested!* That's right. Not only do you get the file you wanted, you also receive a large portion of the data that other hams have requested. You may receive a number of messages and files without transmitting a single watt of RF. All you have to do is listen. That's why they call it "broadcast" protocol. (The one exception to the broadcast method is Fuji-OSCAR 29. It operates more like a traditional packet BBS.)

Station Software

You must run specialized software on your station PC if you're going to enjoy any success with the broadcast-protocol



Bruce Paige, KK5DO, and his daughter Mahana, W5BTS, are both active satellite operators. Bruce is responsible for the Houston AMSAT Net, which you can hear on the Web in RealAudio at <http://www.amsatnet.com/>.

PACSATs. If your computer uses DOS only, you need a software package known as *PB/PG*. *PB* is the software you'll use most of the time to grab data from the satellite. *PG* is only used when you need to upload.

If you're running Microsoft *Windows* on your PC, you'll want to use *WISP*. *WISP* is a *Windows* version of *PB/PG* that includes such features as satellite tracking, antenna rotator control and more. Both software packages are available from AMSAT. And while you're contacting AMSAT, pick up a copy of the *Digital Satellite Guide*. It gets deep into the details of PACSAT operation far beyond the scope of what we can discuss here.

Just the Beginning

This article barely nicks the surface of satellite operating. There is much more to learn and enjoy. I suggest that you spend some time at the AMSAT Web site at <http://www.amsat.org>. You'll pick up a wealth of information there. Speaking of "picking up," grab a copy of the *ARRL Satellite Handbook* (see your favorite dealer, or buy it on the Web at <http://www.arrl.org/catalog/>). Between these two resources you'll be able to tap just about all the amateur satellite knowledge you're likely to need.

In the meantime . . . see you in orbit!

